

DISASSEMBLY

1. REMOVE FILLER PLUG AND DRAIN PLUG WITH GASKETS

Torque: 39 N·m (400 kgf·cm, 29 ft·lbf)

2. REMOVE BACK-UP LIGHT SWITCH WITH GASKET

Torque: 40 N·m (410 kgf·cm, 30 ft·lbf)

3. REMOVE CONTROL CABLE BRACKET

Remove the 2 bolts and control cable bracket.

Torque: 25 N·m (255 kgf·cm, 18 ft·lbf)

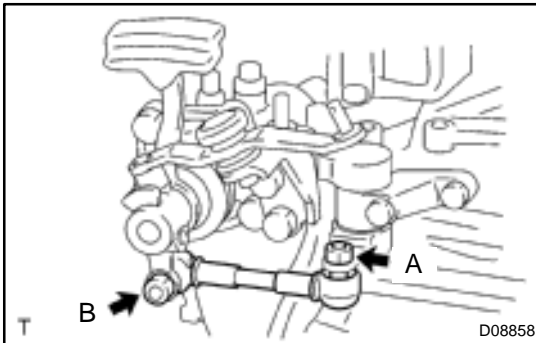

4. REMOVE CONTROL SHAFT ASSEMBLY

(a) Remove the (A) nut and wave washer.

Torque: 12 N·m (122 kgf·cm, 9 ft·lbf)

(b) Remove the (B) nut and the control shaft assembly.

Torque: 12 N·m (122 kgf·cm, 9 ft·lbf)

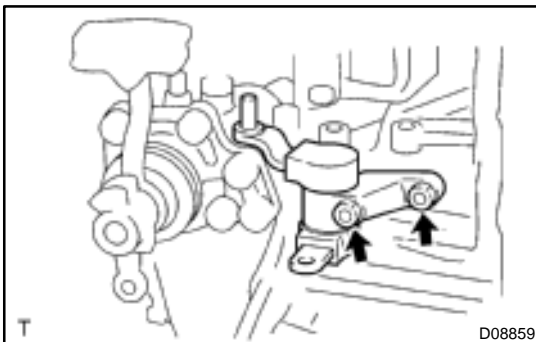

5. REMOVE SELECTING BELLCRANK ASSEMBLY

Remove the 2 bolts and the selecting bellcrank assembly.

Torque: 20 N·m (204 kgf·cm, 15 ft·lbf)

NOTICE:

At the time of reassembly, please refer to the following item.

Fit the selecting bellcrank assembly pin part with the dust cover into a groove in the control shift lever.



6. REMOVE SHIFTING BELLCRANK ASSEMBLY

Remove the 2 bolts and the shifting bellcrank assembly.

Torque: 20 N·m (204 kgf·cm, 15 ft·lbf)



7. REMOVE CONTROL SHIFT LEVER AND DUST BOOT

(a) Remove the nut and wave washer.

Torque: 12 N·m (122 kgf·cm, 9 ft·lbf)

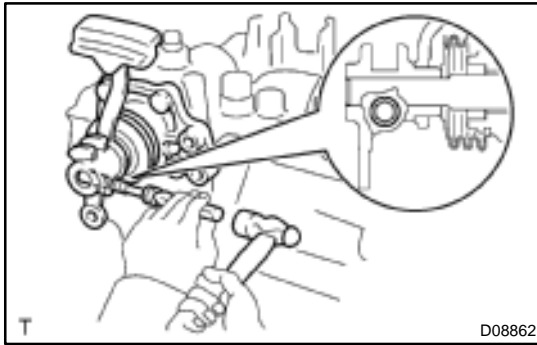

- (b) Using a pin punch and a hammer, tap out the lever lock pin.

NOTICE:

At the time of reassembly, please refer to the following item.

When fixing the lever lock pin, properly position the shaft groove.

- (c) Remove the control shift lever and dust boot.

NOTICE:

At the time of reassembly, please refer to the following items.

- Install the dust boot into a groove in the control shift lever.
- Be sure to install the dust boot in the correct direction, as shown in the illustration.

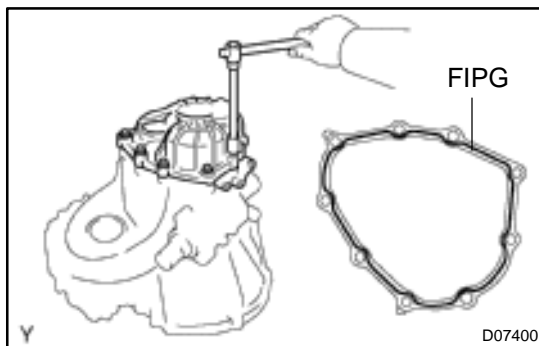
**8. REMOVE TRANSMISSION CASE COVER**

- (a) Remove the 9 bolts.

Torque: 18 N·m (185 kgf·cm, 13 ft·lbf)

- (b) Using a brass bar and a hammer, carefully tap the projection of the transmission case cover to remove the transmission case cover from the transmission case.

HINT:

At the time of reassembly, please refer to the following item. Apply FIG to the transmission case cover as shown in the illustration.

FIG:

Part No. 08826-00090, THREE BOND 1281 or equivalent

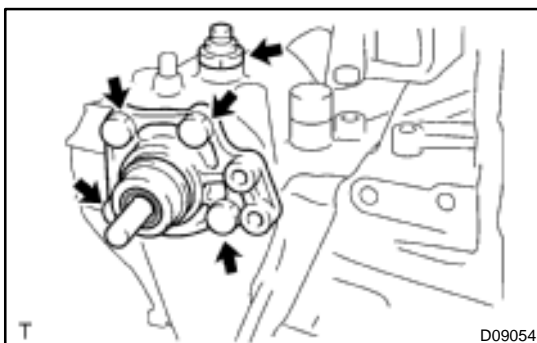
**9. REMOVE LOCK BALL ASSEMBLY AND CONTROL SHAFT COVER**

- (a) Remove the lock ball assembly.

Sealant:

Part No. 08833-00080, THREE BOND 1344, LOCTITE 242 or equivalent

Torque: 29 N·m (300 kgf·cm, 22 ft·lbf)

- (b) Remove the 4 bolts, control shaft cover and gasket.

Sealant:

Part No. 08833-00080, THREE BOND 1344, LOCTITE 242 or equivalent

Torque: 20 N·m (200 kgf·cm, 14 ft·lbf)

10. REMOVE SHIFT AND SELECT LEVER SHAFT ASSEMBLY

NOTICE:

At the time of reassembly, please refer to the following item.

Set the claws of the shift interlock plate into the shift head part of the gear shift fork shaft securely.



11. REMOVE LOCK NUT

- (a) Engage the gear double meshing.
- (b) Using a chisel and a hammer, loosen the staked part of the nut.
- (c) Remove the lock nut.
- (d) Disengage the gear double meshing.

Torque: 118 N·m (1,200 kgf·cm, 87 ft·lbf)

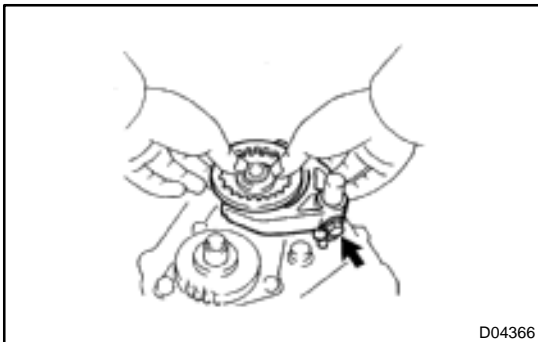

12. REMOVE NO. 3 HUB SLEEVE, NO. 3 CLUTCH HUB AND NO. 3 GEAR SHIFT FORK

- (a) Remove the bolt from the No. 3 gear shift fork.

Torque: 16 N·m (160 kgf·cm, 12 ft·lbf)

Sealant:

Part No. 08833-00080, THREE BOND 1344, LOCTITE 242 or equivalent

- (b) Remove the No. 3 hub sleeve and 3 shifting keys with the No. 3 gear shift fork.

HINT:

At the time of reassembly, please refer to the following items.

- Assemble the No. 3 hub sleeve and No. 3 clutch hub. Install the No. 3 clutch hub and 3 shifting key springs to the No. 3 hub sleeve.
- Install the 2 shifting key springs under the 3 shifting keys.

NOTICE:

Position the key springs so that their end gaps are not aligned.

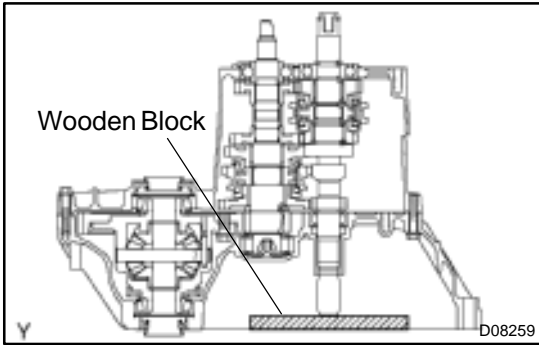

HINT:

At the time of reassembly, please refer to the following items.

- Before driving in the No. 3 hub sleeve and No. 3 clutch hub assembly, place the suitable sized wooden block on the rear side of the input shaft, as shown in the illustration. When driving it in, fix the input shaft firmly so that it is not pushed downward. Otherwise the input shaft rear radial ball bearing is overloaded, it might be damaged.

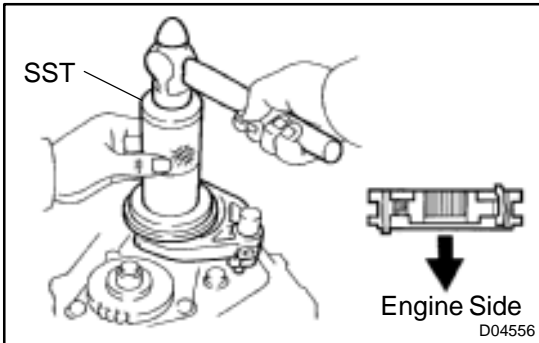

- Using SST and a hammer, tap in the No. 3 hub sleeve and No. 3 clutch hub assembly together with the No. 3 gear shift fork.

SST 09636-20010

NOTICE:

- Be sure to install the No. 3 hub sleeve and No. 3 clutch hub assembly in the correct direction, as shown in the illustration.
- Align the No. 3 synchronizer ring slots with the No. 3 shifting keys.

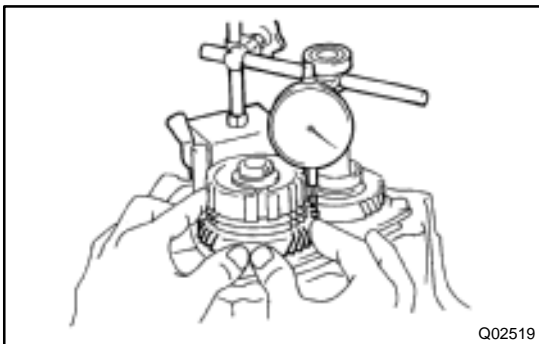

13. INSPECT 5TH GEAR THRUST CLEARANCE

Using a dial indicator, measure the thrust clearance.

Standard clearance:

0.10 – 0.57 mm (0.0039 – 0.0224 in.)

Maximum clearance: 0.57 mm (0.0224 in.)

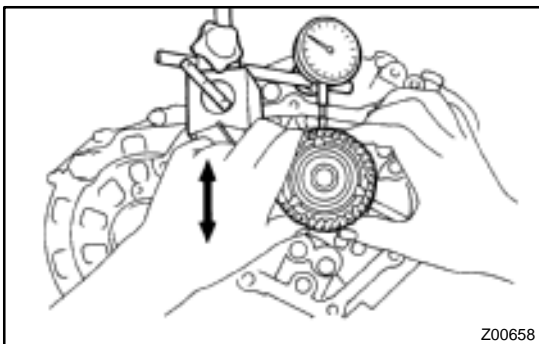

14. INSPECT 5TH GEAR RADIAL CLEARANCE

Using a dial indicator, measure the radial clearance.

Standard clearance:

KOYO made:

0.015 – 0.058 mm (0.0006 – 0.0023 in.)

NSK made:

0.015 – 0.056 mm (0.0006 – 0.0022 in.)

Maximum clearance:

KOYO made: 0.058 mm (0.0023 in.)

NSK made: 0.056 mm (0.0022 in.)

If the clearance exceeds the maximum, replace the gear, needle roller bearing or shaft.

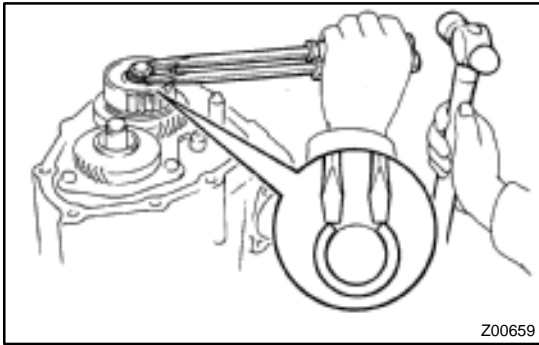

Z00659

15. REMOVE No. 3 CLUTCH HUB AND 5TH GEAR

- (a) Using 2 screwdrivers and a hammer, tap out the snap ring.

HINT:

At the time of reassembly, please refer to the following item. Select a snap ring from the table below that will make the thrust clearance of the No. 3 clutch hub less than 0.1 mm (0.0039 in.).

Mark	Thickness mm (in.)	Mark	Thickness mm (in.)
A	2.25 (0.0886)	E	2.49 (0.0980)
B	2.31 (0.0909)	F	2.55 (0.1004)
C	2.37 (0.0933)	G	2.61 (0.1028)
D	2.43 (0.0957)	–	–

- (b) Using a screwdriver, pry out the shifting key spring from the No. 3 clutch hub.

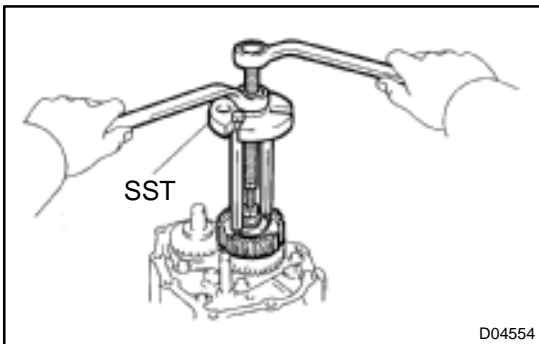

D04554

- (c) Install a bolt and washer to the tip of the input shaft and using SST, remove the No. 3 clutch hub.
SST 09950-30011

HINT:

Select a bolt whose outer diameter is smaller than the screw hole of the input shaft so that it can be turned easily.

- (d) Using a screwdriver, pry out the shifting key spring from the other side of the No. 3 clutch hub.
- (e) Remove the No. 3 synchronizer ring, 5th gear, needle roller bearing and spacer.

16. REMOVE 5TH DRIVEN GEAR

Using SST, remove the 5th driven gear.

SST 09628-62011, 09950-40011 (09957-04010), 09950-60010 (09951-00230)

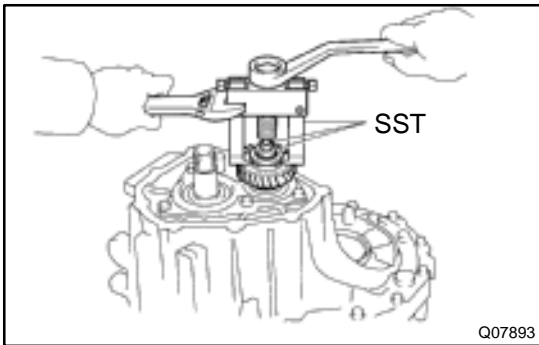

Q07893

HINT:

At the time of reassembly, please refer to the following item. Using SST, install the 5th driven gear.

SST 09309-12020

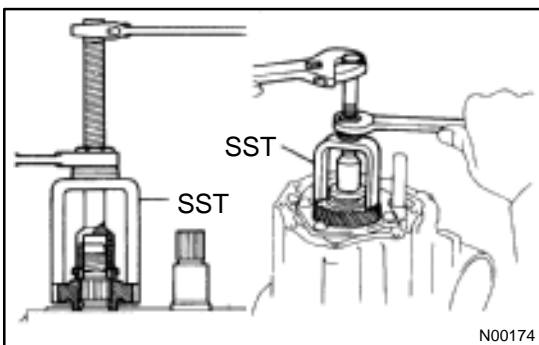

N00174

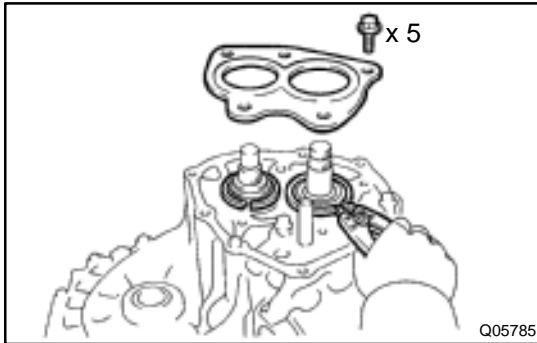
**17. REMOVE REAR BEARING RETAINER**

Remove the 5 bolts and rear bearing retainer.

Sealant:

Part No. 08833-00080, THREE BOND 1344, LOCTITE 242 or equivalent

Torque: 27 N·m (280 kgf·cm, 20 ft·lbf)

18. REMOVE BEARING SNAP RING

Using a snap ring expander, remove the 2 snap rings.

HINT:

If it is difficult to remove and install the snap rings, pull up the shafts.

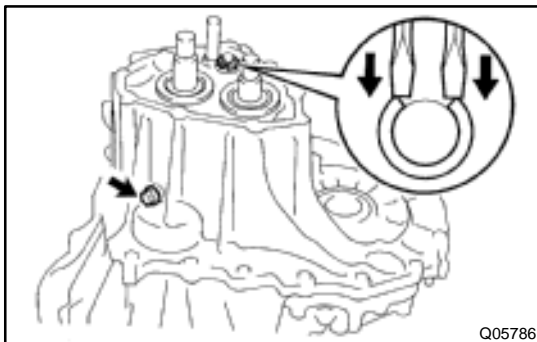
**19. REMOVE REVERSE IDLER GEAR SHAFT LOCK BOLT AND GASKET****Sealant:**

Part No. 08833-00080, THREE BOND 1344, LOCTITE 242 or equivalent

Torque: 29 N·m (300 kgf·cm, 22 ft·lbf)

20. REMOVE SNAP RING FROM NO. 2 SHIFT FORK SHAFT

Using 2 screwdrivers and a hammer, tap out the snap ring.

**21. REMOVE STRAIGHT SCREW PLUG, SEAT, SPRING AND BALL**

(a) Using a hexagon wrench, remove the 3 straight screw plugs.

Sealant:

Part No. 08833-00080, THREE BOND 1344, LOCTITE 242 or equivalent

Torque: 25 N·m (250 kgf·cm, 18 ft·lbf)

(b) Using a magnetic finger, remove the 3 seats, springs and balls.

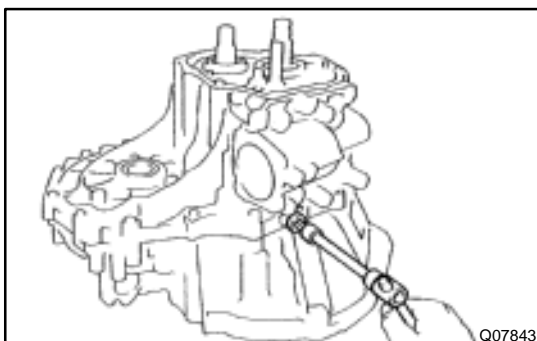
**22. REMOVE LOCK BALL ASSEMBLY**

Using a hexagon wrench, remove the lock ball assembly.

Sealant:

Part No. 08833-00080, THREE BOND 1344, LOCTITE 242 or equivalent

Torque: 39 N·m (400 kgf·cm, 29 ft·lbf)

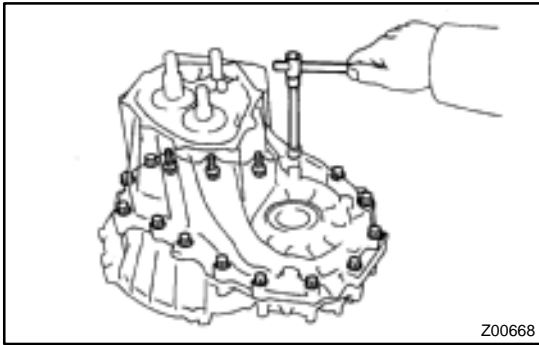

23. REMOVE TRANSMISSION CASE

- (a) Remove the 16 bolts.
Torque: 29 N·m (300 kgf·cm, 22 ft·lbf)
- (b) Using a plastic-faced hammer, carefully tap the projection of the transmission case to remove the transmission case from the transaxle case.

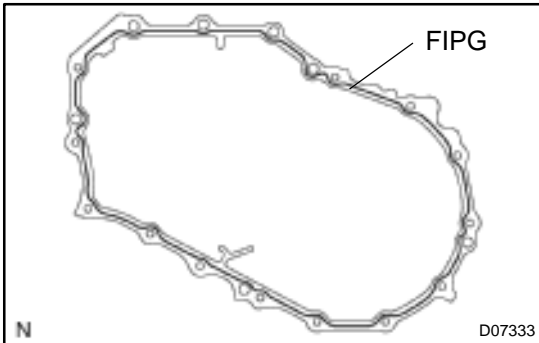

HINT:

At the time of reassembly, please refer to the following item. Apply FIPG to the transaxle case as shown in the illustration.

FIPG:

Part No. 08826-00090, THREE BOND 1281 or equivalent

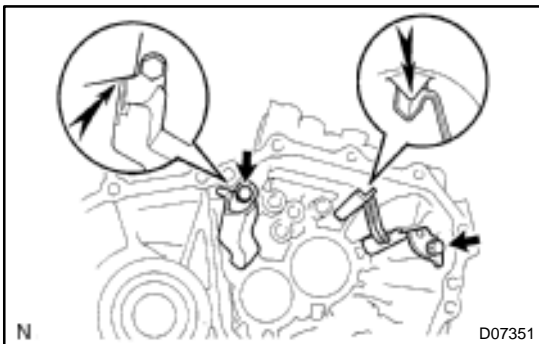

24. REMOVE OIL RECEIVER PIPE

Remove the 2 bolts and 2 oil receiver pipes from the transmission case.

Torque: 17 N·m (175 kgf·cm, 13 ft·lbf)

NOTICE:

At the time of reassembly, please refer to the following items.

- Prevent the oil receiver pipes from being deformed.
- Install the oil receiver pipes while placing it against the transmission case, as shown in the illustration.

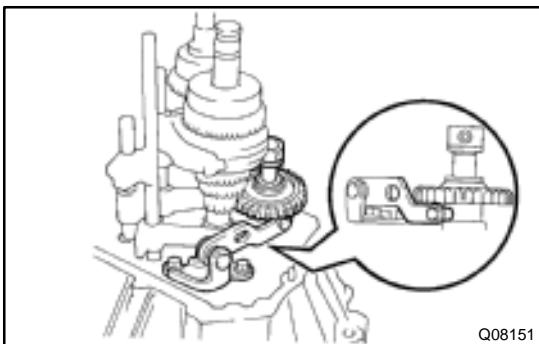

25. REMOVE REVERSE IDLER GEAR, THRUST WASHER AND SHAFT

26. REMOVE REVERSE SHIFT ARM BRACKET

Remove the 2 bolts and reverse shift arm bracket.

Torque: 17 N·m (175 kgf·cm, 13 ft·lbf)

NOTICE:

At the time of reassembly, please refer to the following items.

- Set the pin on the top of the reverse shift arm into a groove on the reverse idler gear.
- Fit the claw of the reverse shift arm bracket with the notch of the input shaft front bearing.

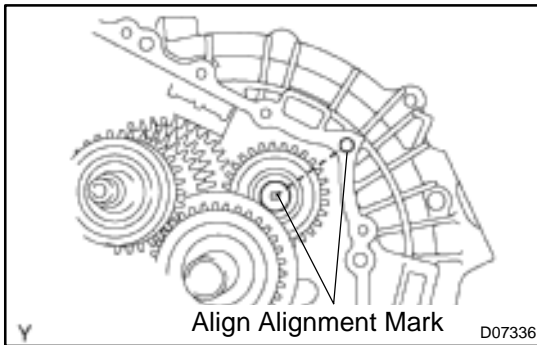

- Install the reverse idler gear, thrust washer and shaft, as shown in the illustration.

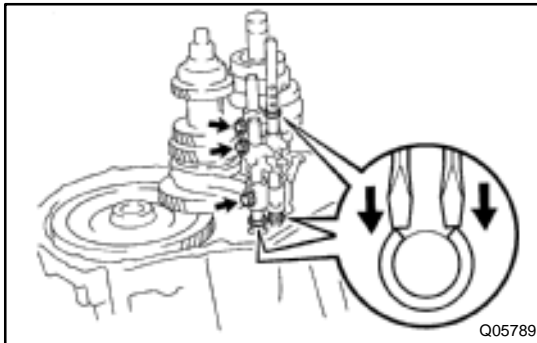

27. REMOVE GEAR SHIFT FORK AND GEAR SHIFT FORK SHAFT

- Using 2 screwdrivers and a hammer, tap out the 3 snap rings from each gear shift fork shaft.
- Remove the 3 bolts from the No. 1 gear shift head, No. 1 and No. 2 gear shift forks.

Sealant:

Part No. 08833-00080, THREE BOND 1344, LOCTITE 242 or equivalent

Torque: 16 N·m (160 kgf·cm, 12 ft·lbf)

- Pull up the No. 3 gear shift fork shaft, remove the No. 2 gear shift fork shaft.

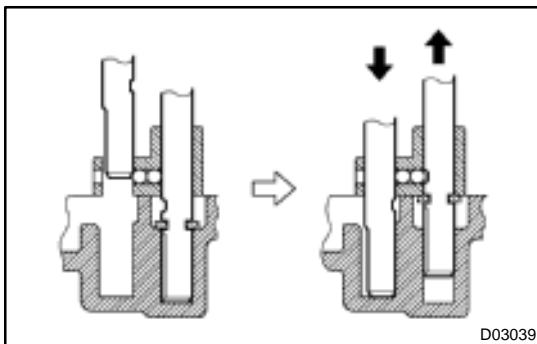

NOTICE:

At the time of reassembly, please refer to the following item.

To avoid the interference of the 2 balls, lift up the No. 3 gear shift fork shaft at the position shown in the illustration.

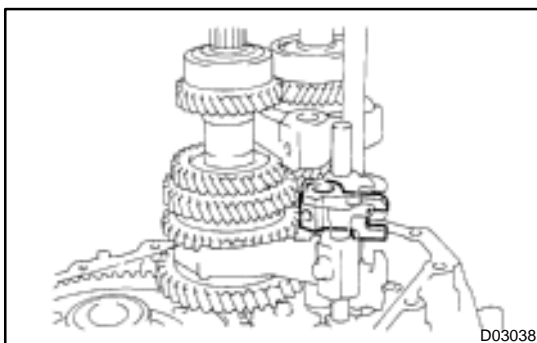

- Remove the No. 1 gear shift head.

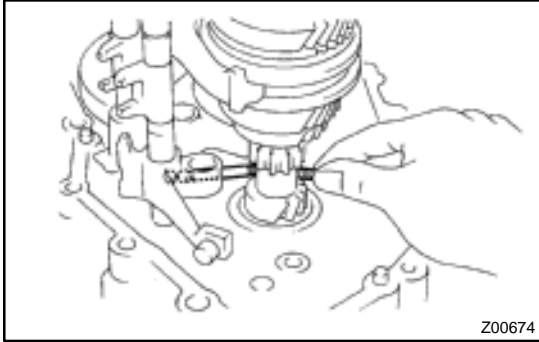

- (e) Using a magnetic finger, remove the 2 balls from the reverse shift fork.
- (f) Remove the No. 3 gear shift fork shaft and reverse shift fork.
- (g) Pull out the No. 1 gear shift fork shaft.
- (h) Remove the No. 1 and No. 2 gear shift forks.

28. REMOVE INPUT AND OUTPUT SHAFTS TOGETHER FROM TRANSAXLE CASE

29. REMOVE DIFFERENTIAL CASE ASSEMBLY

NOTICE:

At the time of reassembly, please refer to the following item.

Before reassembly, inspect the differential tapered roller bearing preload (See page [MX-50](#)).

30. REMOVE MAGNET FROM TRANSAXLE CASE